

Memorandum



CITY OF DALLAS

DATE August 6, 2010

TO Members of the Transportation and Environment Committee:
Linda Koop (Chair), Sheffie Kadane (Vice Chair), Jerry R. Allen, Tennell Atkins,
Carolyn R. Davis, Delia Jasso, Pauline Medrano, Ron Natinsky,
Vonciel Jones Hill

SUBJECT Streetcar and Public Service Provider Coordination Within Public Right of Way

Attached is the "Streetcar and Public Service Provider Coordination Within Public Right of Way" briefing that will be presented to you on August 10, 2010. It provides information related to the dialogue between the City, DART, and Public Service Providers (Oncor, Atmos, AT&T, Dallas Water Utilities, others) to outline the criteria, rules, and on-going cooperative relationship for franchise utilities and other Public Service Providers operating in the vicinity of existing and proposed streetcar routes.

Please contact me if you need additional information.

A handwritten signature in black ink, appearing to read 'Jill Jordan'.

Jill A. Jordan, P.E.
Assistant City Manager

c: The Honorable Mayor and Members of the City Council
Mary K. Suhm, City Manager
Thomas P. Perkins, Jr., City Attorney
Deborah Watkins, City Secretary
Craig Kinton, City Auditor
Judge C. Victor Lander, Administrative Judge
Ryan S. Evans, First Assistant City Manager
A.C. Gonzalez, Assistant City Manager
Forest E. Turner, Assistant City Manager
Jeanne Chipperfield, Chief Financial Officer
Edward Scott, Director, Controller's Office
Helena Stevens-Thompson, Assistant to the City Manager – Council Office
Rick Galceran, P.E., Director, Public Works and Transportation

Streetcar and Public Service Provider Coordination Within Public Right of Way



Presented to the
Transportation and Environment Committee

By Public Works and Transportation
August 10, 2010





Purpose

- Update Committee on the coordination between the City and Public Service Providers (Oncor, Atmos, AT&T, Dallas Water Utilities, others)
- Outline the criteria, rules, and on-going cooperative relationship for franchise utilities and other Public Service Providers (PSPs) operating in the vicinity of streetcars



Background

- Previous streetcar extension projects encountered conflicts with existing underground utilities
 - Physical conflicts
 - Conflicts related to PSP staff safety due to desired separation distance from rail
- Result was costly relocations, time delays, and interference with streetcar operations
- Original downtown loop and extension to the West End was never completed due to extensive underground utility conflicts



Background (cont'd)

- Multiple corridors are currently being considered for future extensions
 - Olive Street Extension
 - Urban Circulator Loop (St. Paul, Federal, Olive)
 - Oak Cliff / Methodist Hospital
 - Additional downtown lines
- Existing documents (Street Cut Manual, Franchise Agreements, etc.) have no provisions for the interface between streetcars and PSPs
- City staff began meeting with public service providers in early 2008 to forge a cooperative relationship



Background (cont'd)

- In October 2008, City and DART staff accompanied Onco personnel to Portland, Oregon to observe the Portland streetcar system
- City Attorney's Office advised that a good approach would be to:
 - Amend City Chapter 43-136 of Dallas City Code to authorize the Director of Public Works and Transportation to promulgate appropriate rules
 - Incorporate the rules, with ample flexibility, into an operating manual for use by the PSPs
- Taskforce meetings to address language in the manual continue between the City, McKinney Avenue Transit Authority (MATA), DART, and the PSPs



Proposed Streetcar Operating Manual

- Purpose
 - Establish appropriate criteria for Public Service Provider operation and maintenance in the vicinity of streetcars
- Authorization
 - Amend the Dallas City Code to authorize the Director of Public Works and Transportation to promulgate a Streetcar Operating Manual
- Application
 - Apply the procedure to all streetcar projects, current and future

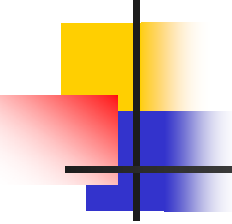

Proposed Streetcar Operating Manual (cont'd)

■ Urgency

- Existing routes
- Olive Street Extension ready to begin construction
- Urban Circulator Loop ready to begin design; to be operational by 2013

■ Method

- Appendix to the current *City of Dallas Pavement Cut and Repair Standards Manual*
- Input from PSP representatives at the Streetcar Task Force meetings
- Reviewed and formatted by the City Attorney's Office



Proposed Streetcar Operating Manual

Key Guidelines for Utility Operation

- Requires PSPs to provide 48-hour notice and obtain a permit prior to performing work within the “Power Safety Envelope” of the streetcar
 - Permit will be issued through DART’s 24-hour operations center
 - Preference will be for utility work to be performed at night, but, by exception for emergency, during streetcar revenue service hours
 - Consideration being given to determine methods whereby notice and receipt of permit can be expedited for various activities (i.e. – routine inspections)

Proposed Streetcar Operating Manual

Key Guidelines for Utility Operation (Cont'd)

- Power Safety Envelope
 - A track access permit will be required for any utility work performed within the Power Safety Envelope
 - No track access permit required outside of the envelope

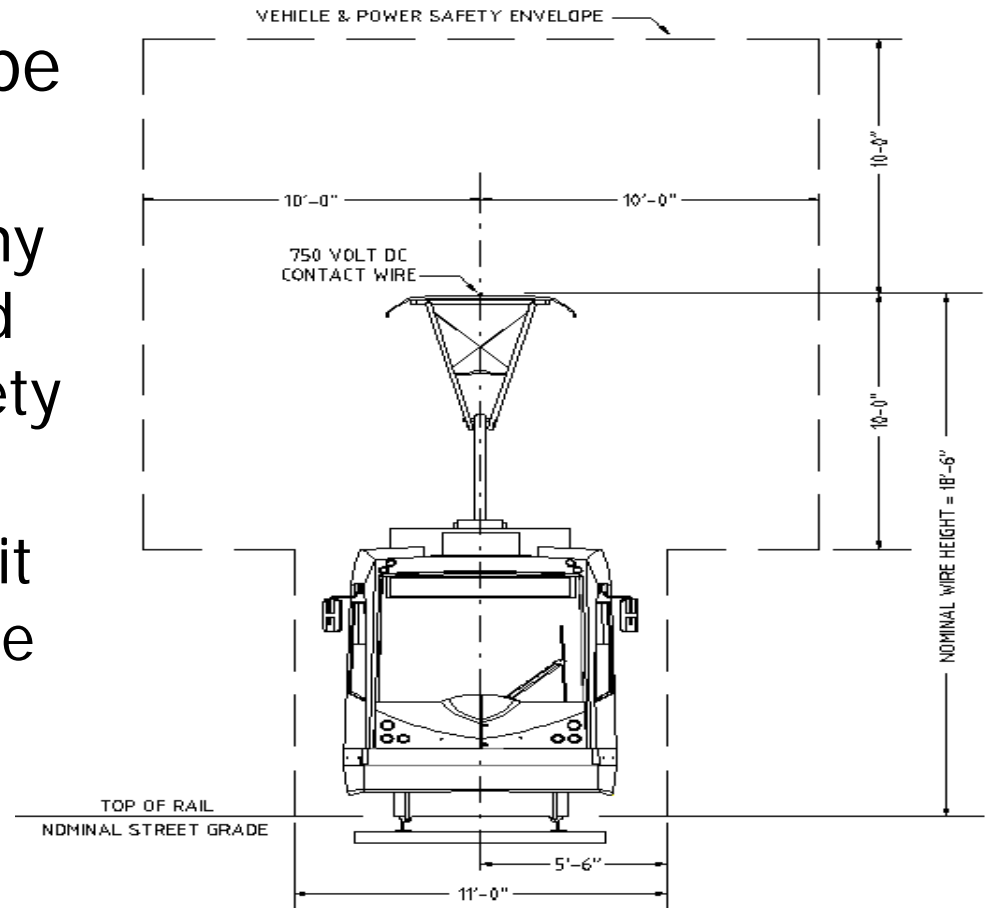



Proposed Streetcar Operating Manual

Key Guidelines for Utility Operation (Cont'd)

- Track Access Permit
 - Issued through DART's 24-hour operations center
 - Simple, one-page form
 - Tailored after Portland's permit and permitting system
 - Step by step process with contact information to be outlined for ease of use



Proposed Streetcar Operating Manual

Key Guidelines for Utility Operation (Cont'd)

- Immediate track access to be provided for emergency conditions (already defined by Dallas City Code): service outages, wet cables, cut or damaged facilities, Homeland Security concerns
- Flagmen will be present during all utility construction work for safety to workers, streetcar operators, and the traveling public
- Task force to remain intact
 - Convene meetings quarterly during first year to determine modifications that may be needed to Operating Manual
 - As needed thereafter



Next Steps

- August 11, 2010
 - Authorize amendment to the Dallas City Code for the Director of Public Works and Transportation to promulgate rules (Streetcar Operating Manual)
- August 25, 2010
 - Authorize construction contract for Olive Street Extension
- September / October 2010
 - Finalize the Streetcar Operating Manual



Questions / Discussion





Appendix

Downtown Streetcar Projects

McKinney Avenue, Olive Street Extension and Urban Circulator Loop

